

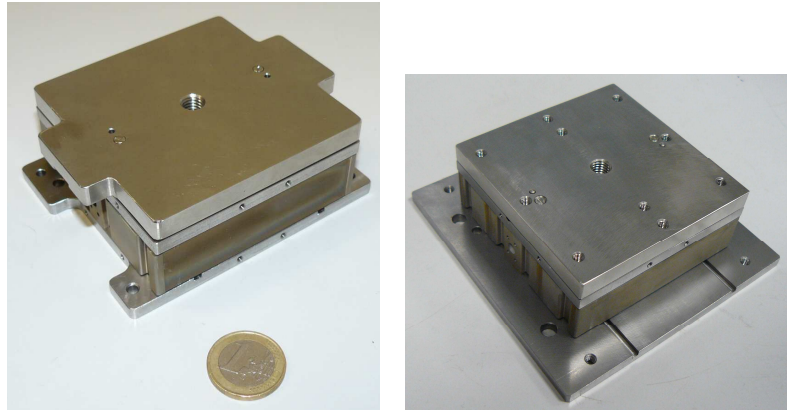

ISP 09R025FPI0022 D

Electromagnetic Wide Range Nano Positioning Table **TEMNP XY 10-5-0.5**

This table ensures highly precise displacements on two orthogonal axes.



Non contractual pictures

Design :

Axes are put in motion through an electromagnetic linear motor. Guidance is made by a mechanism of deformable elements.

This concept offers many advantages: no parasite frictions, backlash-free, high precision and repeatability, no maintenance, compatibility with special environments (clean rooms, high-vacuum and ultra-high-vacuum), low heat generation even after a long period of utilization.

TEMNP stages have nanometric resolutions on millimetric travel-range. This technology is very compact and easy-to-use.

The assembly process and its linear behaviour make this stage able to be used as an absolute displacement table. This solution increases reliability and robustness.

Equipped with a displacement sensor, this table allows a force control with no need of a force sensor.

This product is patented by ISP System

Applications :

- Precise positioning of small parts.
- AFM / SEM Microscopy.

Références :

- Sample scanning.
- Micro-electronic controlled nanometric displacement in high-vacuum (UV) or Ultra High-Vacuum (UHV).

ISP SYSTEM SA • Headquarters : ZI de la Herray - B.P. 10047 • 65501 VIC-en-BIGORRE - FRANCE
Tél : +33 (5) 62 33 44 44 • Fax : +33 (5) 62 33 44 45 • e-m@ail : contact@isp-system.fr
RCS Tarbes B 410 675 078 • SIRET 410 675 078 00027 • APE 742 C

This document is property of ISP System, it cannot be used, reproduced or divulged without any prior written agreement.



Electromagnetic Wide Range Nano Positioning Table TEMNP XY 10-5-0.5

Axis Technical Specifications :

Dimensions (I x L x H)	120 mm x 120 mm x 50 mm
Travel range	Up to 10 mm
Displacement resolution	5 nm to 50 nm
Force (optional)	+/- 5 N
Force resolution (optional)	Up to 1 mN
Maximum load	0,5 Kg
Straightness and flatness	200 nm RMS
Speed	0,001 to 1 mm/s (2 mm/s for coarse displacements)
Repeatability	200 nm RMS
Work in vacuum (optional)	Ultra high vacuum (10^{-10} Torr)

Electronic control architecture :

Presentation

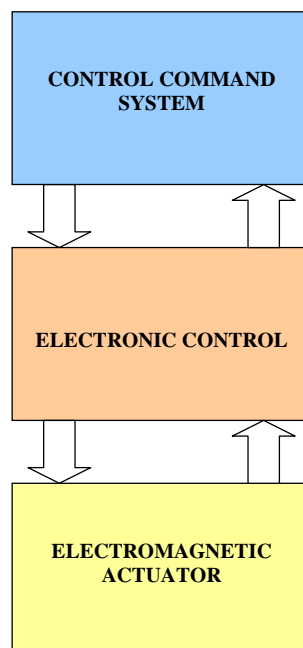

Electronic control and electromagnetic actuator are parts of the ISP SYSTEM supplies. However, control command system is a software application which must be developed by the customer or by ISP SYSTEM through further study.



Electromagnetic Wide Range Nano Positioning Table TEMNP XY 10-5-0.5

Functional diagram

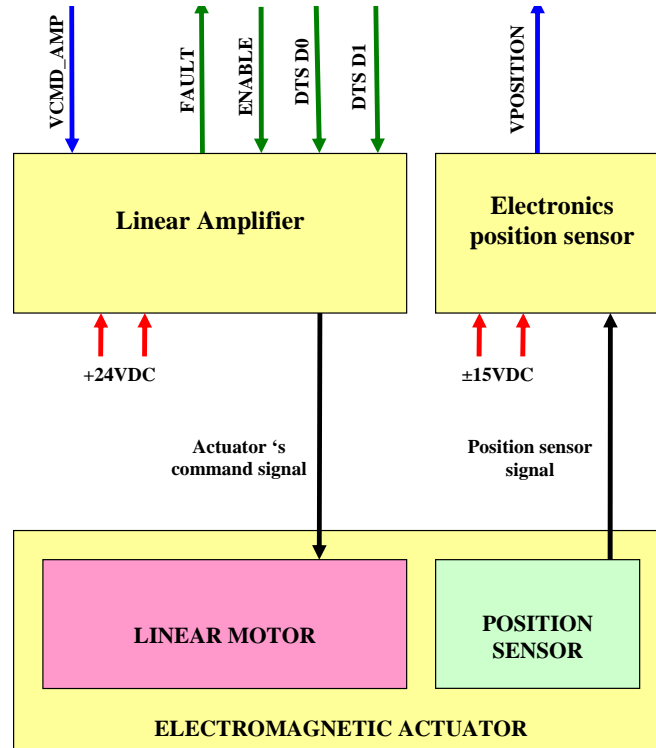

To simplify the architecture, the actuator is represented by two simple elements:

- 1 linear motor.
- 1 position sensor.

The actuator is driven by an electronic motion control composed by:

- 1 power stage for motor control.
- 1 processing and shaping stage of the signal generated by sensor.

Diagram legend:

- **GREEN:** digital signal.
- **BLUE:** analog signal processed/generated by control command system.
- **RED:** supply signal.
- **BLACK:** analog signal which is not processed/generated by control command system.

Signals definition table:

Signal	Property	Type	Sens	Voltage range
VPOSITION	Actuator position	Analog	Input	0-10V
VCMD_AMP	Linear amplifier command signal	Analog	Output	±10V
FAULT	Linear amplifier fault signal	Digital	Input	TTL
ENABLE	output enable for linear amplifier	Digital	Output	TTL
DTS_D0	D0 data for linear amplifier selector (DTS mode)	Digital	Output	TTL
DTS_D1	D1 data for linear amplifier selector (DTS mode)	Digital	Output	TTL



Electromagnetic Wide Range Nano Positioning Table **TEMNP XY 10-5-0.5**

DTS mode, for Dynamic Transconductance Selection, enables on-the-fly changes to the transconductance settings. This is accomplished by logically controlling the DTS_D0 and DTS_D1 bits.

Linear amplifier characteristics

Linear amplifier is the motion control system used to drive electromagnetic actuator. Actuator is controlled in current by linear amplifier which is driven by an analog signal. It has the following characteristics:

- Supply: 15VDC à 48VDC
- Command signal: ± 10 VDC
- Digital signals: TTL

Position sensor characteristics

The electronics needed to process the signal generated by sensor has the following characteristics:

- Supply: ± 15 VDC $\pm 2\%$
- Output voltage: 0-10VDC
- Sensor range: 0-2mm

Specifications can be modified to meet your requirements (please contact us).